

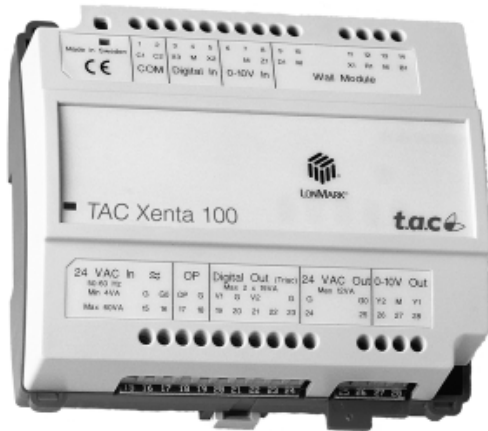

TAC Xenta® 102-VF

VAV Controller with Valve Reheat

4 Sep 2002



TAC Xenta® 102-VF is a zone controller for VAV heating and cooling applications that use fan on/off control and modulating valve reheat.

The controller keeps a constant temperature by controlling the air flow with the aid of a Belimo® VAV Compact; a valve reheat coil is used for the heating stage. Through a carbon dioxide sensor, the air quality can be controlled in the zone.

The controller is a LONMARK®-compliant device that communicates on a LONTALK® TP/FT-10 network via a twisted-pair, unpolarized cable. It is able to operate both as a stand-alone unit and as part of a system. All network variables can be monitored and configured via the TAC Xenta OP, if the OP version is 3.11 or higher.

ZS 100 is a range of wall modules intended to be used together with TAC Xenta 102.

There are plug-in terminal blocks available for the TAC Xenta 100 series that can be attached to the existing terminals.

TECHNICAL DATA

Supply voltage 24 V AC -10% +20%, 50-60 Hz

Power consumption:

Controller with TAC Xenta OP 4 VA

Actuator supply max. 12 VA

Digital output max. 19 VA

Total max. 35 VA

Ambient temperature:

Operation 0 to 50 °C (32 to 122 °F)

Storage -20 to 50 °C (-4 to 122 °F)

Humidity max. 90% RH, non-condensing

Enclosure:

Material ABS/PC plastic

Enclosure rating IP 30

Color grey/red

Dimensions 122 x 126 x 50 mm (4.8 x 5 x 2 in)

Weight 0.4 kg (0.88 lbs)

Inputs for occupancy sensor and window contact, X2-X3:

Voltage across open contact 23 V DC ± 1 V DC

Current through closed contact 4 mA

Minimum pulse input duration X2/X3 250 ms / 15 s

Output for fan on/off control, V1:

Minimum output voltage supply voltage - 1.5 V

Maximum load 0.8 A

Input for bypass button on wall module, X1:

Minimum pulse input duration 250 ms

Maximum current, LED 2 mA, for ZS 100 series

Input for temperature sensor, B1:

Thermistor type NTC, 1800 Ω at 25 °C (77 °F)

Measuring range -10 to 50 °C (14 to 122 °F)

Accuracy ±0.2 °C (±0.36 °F)

Inputs for air flow and carbon dioxide sensor, Z1-Z2:

Measuring range 0-10 V DC

Accuracy ±0.05 V

Input setpoint adjustment on wall module, R1:

Type 10 kΩ linear potentiometer

Adjustment range ±5 °C (±9 °F)

Accuracy ±0.1 °C (±0.18 °F)

Outputs for air flow controller and reheat actuator, Y1-Y2:

Output range 0-10 V DC

Maximum current 2 mA

Accuracy ±0.2 V

Application program:

Cycle time 15 s

Indication LED colors:

Power green

Service red

Interoperability:

Standard conforms to LONMARK Interoperability Guidelines and LONMARK Functional Profile: VAV Controller

Communication protocol LONTALK

Physical channel TP/FT-10, 78 kbps

Neuron® type 3150®, 10 MHz

Conformance to standards:

Emission C-Tick, FCC Part 15, EN 50081-1

Immunity EN 50082-1

Safety:

CE EN 61010-1

UL 916 Energy Management Equipment

ETL listing UL 3111-1, first edition

..... CAN/CSA C22.2 No. 1010.1-92

Flammability class, materials UL 94 V-0

Part number, TAC Xenta 102-VF:

Controller 0-073-0535

Manual (GB) 0-004-7516

Plug-in Terminal Blocks TAC Xenta 100 0-073-0914



APPLICATION EXAMPLE

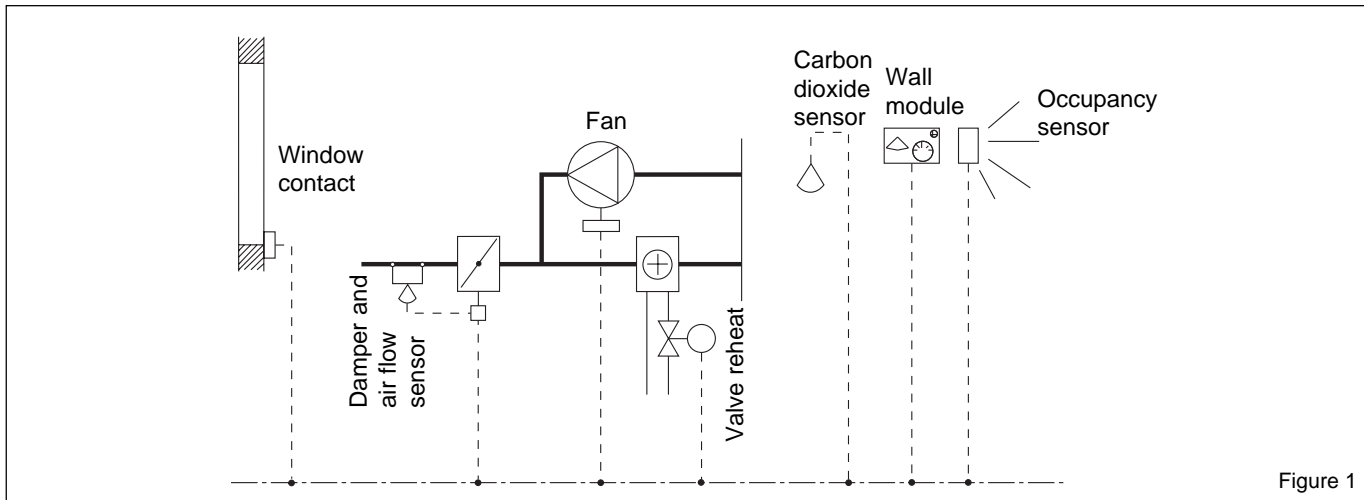

Figure 1

FUNCTIONS

The function of TAC Xenta 102-VF is determined by the occupancy mode, the application mode, the emergency mode, the manual mode and the node state.

The airflow and a valve reheat coil are controlled to maintain the zone temperature in sequence. The airflow increases when the cooling demand increases. If the cooling demand in the zone decreases, the valve reheat is started, and the fan runs (if a fan is enabled). Furthermore, the airflow is set to its minimum value with a fan, and the minimum heat value without a fan.

Air quality control

In order to maintain the air quality, the controller selects the highest of three possible air flow values: the air flow ordered from the cooling sequence, the air quality control or the set minimum air flow. When carbon dioxide concentration is high, the airflow is set from the air quality control (see figure 3); at other times, it is set by the temperature control sequence. The air quality control is enabled in the occupied and bypass modes.

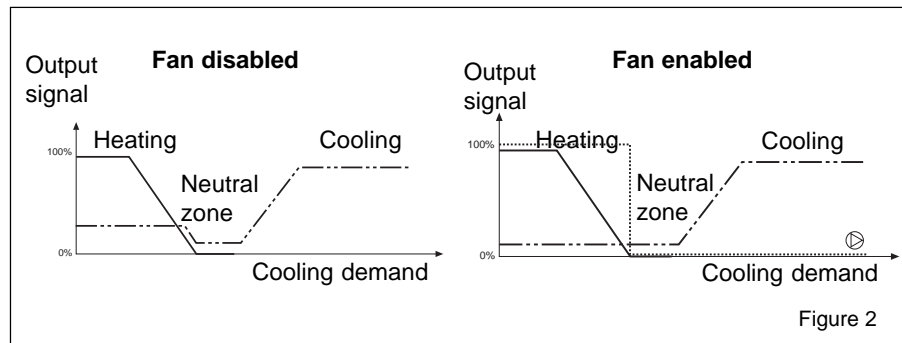

Figure 2

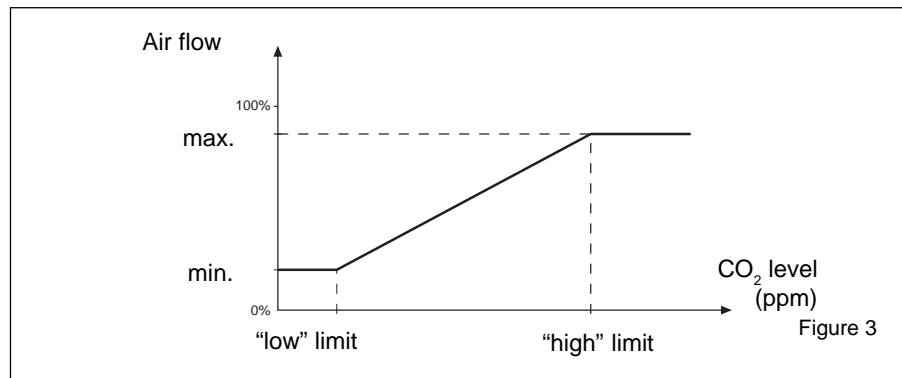

Figure 3

OPERATING MODES

Occupied mode

Occupied mode is used when the zone is occupied. This mode is also the default mode after a reset or a power up. The fan is on if it is enabled and the heating stage is active.

Standby mode

The standby mode reduces energy consumption when enabled. In this mode, the neutral zone is larger than that of the occupied mode, and the airflow is diminished from "minimum occupied airflow" to "minimum standby airflow".

Bypass mode

To bypass the centrally set standby mode, press the bypass button on the wall module, upon which the controller switches to occupied mode. When two hours have passed, the controller reverts to standby mode.

Unoccupied and off modes

The controller stops running when centrally ordered, when a window is opened or slave mode is enabled. The damper is fully closed.

Slave mode

The following occurs when the network variable *nciAppOptions* enables the slave mode:

The slave controller goes into off mode and receives copies of output signals from the master controller.

In slave mode, both the slave and master controllers must be equipped with identical auxiliary units.

OPERATING MODES (CONT'D.)

Night purge mode

In night purge mode, the airflow is set to its maximum value in order to cool the zone with night air. The heating is off.

EMERGENCY MODE

Emergency mode must be manually set and has two different settings:

Shutdown mode

The damper is fully closed.

Purge mode

The air flow is set to its nominal value, which equals a fully open damper.

When emergency mode is not enabled, the network variable is set to normal control.

INSTALLATION

The controller may be mounted on a DIN rail or fastened onto a ceiling or a wall. Two sockets are provided for that purpose.

Cable lengths

Communication cables: refer to the TAC Xenta Network Guide, part number 0-004-7460.

Other cables: maximum length 30 m (100 ft), minimum cross-sectional area of 0.7 mm² (20 AWG) applies to all other cables and all other equipment. The cables are to be twisted, but not shielded.

CONFIGURATION OPTIONS

By changing the network variable *nci-AppOptions* (see figure 4), it is possible to achieve different options in TAC Xenta 102-VF.

The controller's default setting disables all auxiliary units. Below is a list of the different options:

- Occupancy sensor enabled/disabled
- Window contact enabled/disabled
- Fan enabled/disabled
- Air quality controller enabled/disabled
- Slave mode enabled/disabled
- Occupancy sensor normally open/ normally closed

LONMARK OBJECTS AND NETWORK VARIABLES

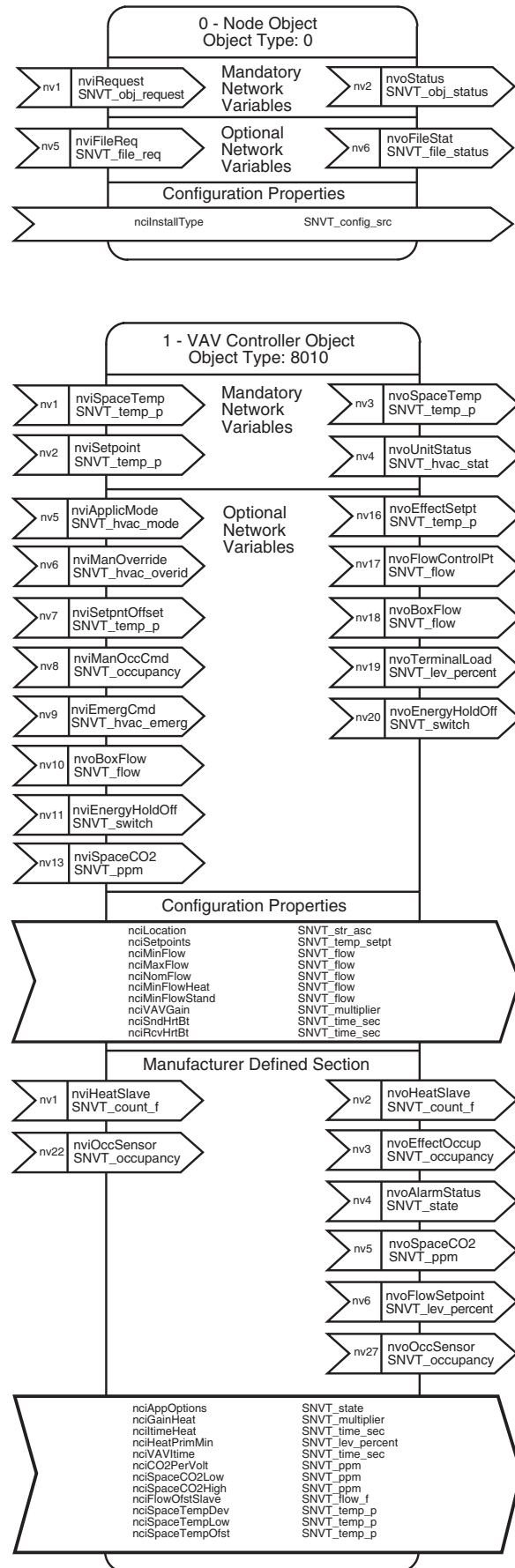

Figure 4

HARDWARE INTERFACE

No.	Designation	Description	No.	Designation	Description
1	C1	TP/FT-10 communication channel	15	G	24 V AC (G) input
2	C2	TP/FT-10 communication channel	16	G0	24 V AC (G0) input
3	X3	Input, window contact	17	OP	24 V AC supply for TAC Xenta OP
4	M	Measurement neutral	18	G	24 V AC supply for TAC Xenta OP
5	X2	Input, occupancy sensor	19	V1	Fan on-off control
6	Z2	Input, carbon dioxide sensor	20	G	24 V AC (G) output
7	M	Measurement neutral	21	G0	24 V AC (G0) output
8	Z1	Input, air flow	22	Y2	Reheat valve actuator
9	D1	Output, indication on wall module	23	M	Measurement neutral
10	M	Measurement neutral	24	Y1	Air flow controller setpoint
11	X1	Input, bypass button on wall module	25	—	Not used
12	R1	Input, setpoint offset dial on wall module	26	—	Not used
13	M	Measurement neutral	27	—	Not used
14	B1	Input, temperature sensor	28	—	Not used

DIMENSIONS

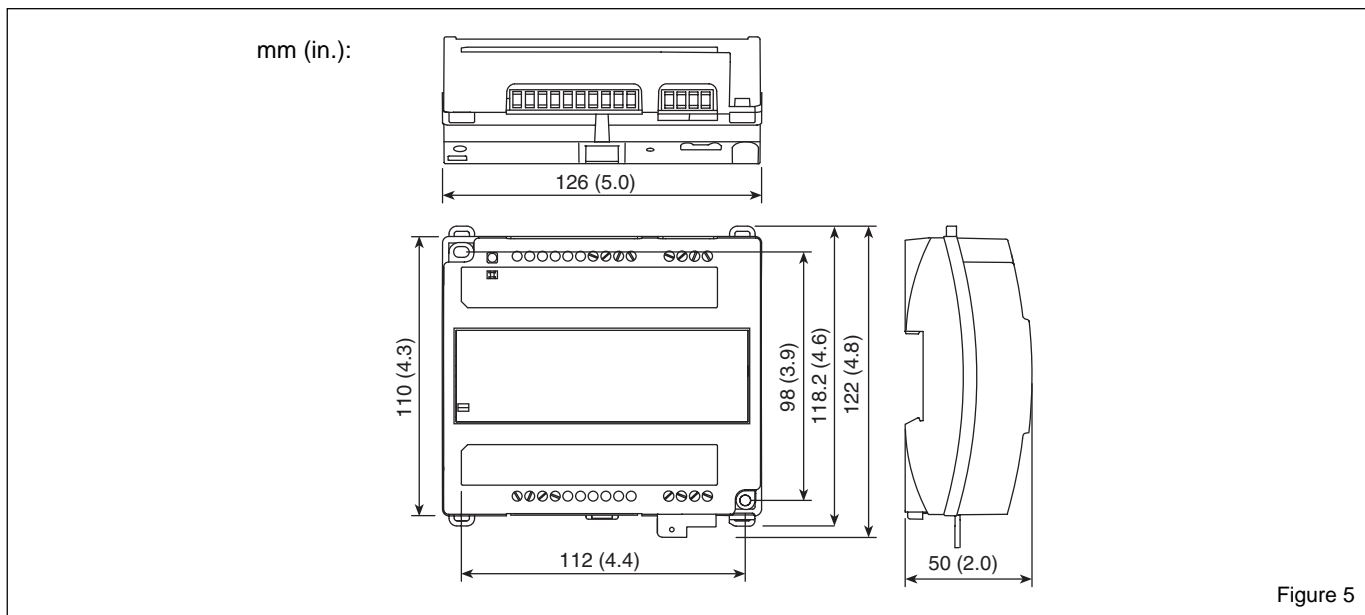

Figure 5

WALL MODULES

Designation	Description	Part number
Sensor Zone ZS 101	Wall module with temperature sensor, mode indication LED and OP connector	0-073-0908
Sensor Zone ZS 102	Wall module with temperature sensor, mode indication LED, setpoint dial and OP connector	0-073-0909
Sensor Zone ZS 103	Wall module with temperature sensor, mode indication LED, bypass button and OP connector	0-073-0910
Sensor Zone ZS 104	Wall module with temperature sensor, mode indication LED, bypass button, setpoint dial and OP connector	0-073-0911

TAC and TAC products are trademarks and/or registered trademarks of TAC AB.
All other trademarks belong to their respective owners. Copyright 2002 © TAC AB. All rights reserved.